



Glide Cruisers, USA
P.O. Box 937
Folsom, CA 95763

Phone: 916.817.1570
Toll Free: 866.766.9653



Glide Cruisers, USA

Owner's Manual

For Models: Calisto, Europa & Solaris

V1.1





Glide Cruisers, USA

P.O. Box 937
Folsom, CA 95763

Phone: 916.817.1570

Toll Free: 866.766.9653

email support:

support@glidecruisers.com

Digital version of this manual located at
www.glidecruisers.com/manuals

Owner's Info:

Date: _____

Model: _____

Serial #: _____

Color: _____

Table of Contents

- 1. Before You Glide (quick reference) Pg 3
- 2. Operation & Safety Pg 5
- 3. Cruiser Model Overview Pg 9
- 4. Model Specifications Pg 10
- 5. Component Definitions Pg 11
- 6. Diagram of Components Pg 13
- 7. APM Computer Console Pg 15
- 8. General Maintenance Pg 19
- 9. Battery Care & Maintenance Pg 21
- 10. Trouble Shooting Pg 23
- 12. Warranty Information..... Pg 26

Congratulations on the purchase of your new Glide Cruiser! Before you start riding please take a moment to make sure that you understand the capabilities and limitations of your new ride.

Before You Glide

Check Equipment

Take a quick look at your Glide to make sure that nothing looks out of place. Although there aren't many things to be concerned with, it is good to have "peace of mind" before you ride. First thing to verify are the tires and brakes. Make sure that the tires are adequately inflated (45 - 50 PSI) and that the brakes work properly. Check the front brake by lifting the front tire off the ground, spinning the tire and clamping the brake lever. For the rear brake (making sure kickstand is down) spin the tire manually or by using the throttle -- test the rear brake. Lastly, verify your battery charge and operation of the motor. Simply turn the key on and check the motor by pressing the thumb throttle (partially down) to verify movement of the motor. All units are shipped with a full charge and should be ready to ride. To be sure - feel free to conduct additional charging.

Plan Your Ride

Distance, weather conditions and terrain are all important factors to consider when riding your Glide. Glide Electric Cruisers are not designed for off-road terrain unless the trail or road is relatively flat with no obstacles. The Glide frame has little ground clearance and is designed for low-center of gravity operation. Ideal riding terrain is paved bicycle lanes or bike trails. Some cities or counties have regulation preventing operation of electric bikes and scooters on bike trails. However, most do allow electric scooters - under which the Glide is classified. Further, the maximum speed for most US cities (regulation) is 20MPH. Just be aware of your own riding regulations and restrictions. If you would like to limit the maximum speed of your motorm consider our optional APM console.

Depending on which battery you have, your Glide will have variable capabilities for total distance. Other factors are constant speed, hills, rider weight and fluctuation of throttle acceleration. If your destination has A/C power and you are concerned about running low on your charge - we recommend that you bring your charger and restore the charge mid-way through your ride if possible. Otherwise plan your trip with reasonable distance expectations. We do have a general distance & speed chart for reference (located at our website /manuals).

Lastly, the weather is an important factor when planning your ride. If it is raining or going to rain - we do not recommend that you ride your Glide. Water and electronics do not mix well and should you get water in the throttle, controller or battery components - it CAN cause malfunction! If you are caught in the rain or must ride in the rain - we suggest that you make sure at minimum that the throttle and controller are both covered with plastic or some other waterproof material. Avoid riding through puddles.

Basic Operation

1. Turn the key on and place your hands on the grips while resting your fingers on the brake levers. (Tip 1 : always ride with a helmet)
2. Place your dominant foot on the footboard slightly off to one side - making room for the other foot. (Tip 2: never with two people)
3. Press the thumb throttle down (only down) slowly as you push off with your ground foot. Then place your loose foot on the deck. Find your comfortable position. It is important to press the throttle *smoothly & slowly* since it can make your start a little jerky otherwise.
4. Brakes should be applied "evenly" during your ride. This is very important since applying only the "front brake" can cause the rider to be lunged forward. The rear brake rotor is larger in diameter in order to yield more stopping power to the rear since most of the cruiser weight is to the rear.

--- We wish you many hours of happy & safe riding!

Operation & Safety

Operating Guidelines:

- Battery:** Make sure your battery is fully charged and that you have a plan for your trip - distance, time, weather, etc. (see "Before you Glide" - page 3).
- Components:** Make sure that you are familiar with the operating components of your cruiser before riding. (see diagram pg 13)
- Brakes:** Always apply relatively equal pressure to both front and back brake levers when slowing down or stopping. This is very important since applying only the "front brake" can cause the rider to be lunged forward. The rear brake rotor is larger in diameter in order to yield more stopping power to the rear wheel since most of the cruiser weight is to the rear.
- Key & Power:** The keyswitch panel is convenient to reach at the upper part of the frame. Only switch the key to the "on" position when stopped. When the key is on - the power light at the throttle will come on (or the APM will light up for those with upgraded APM modules). There is also an "on" switch at the bottom of the controller and a corresponding little red light at the top. This switch is set to "on" from the factory but is available as an extra safeguard off switch.
- Throttle:** Always ease pressure on to the thumb throttle. Press it down (only down) slowly as you push off with your ground foot. Then place your loose foot on the deck. Find your comfortable position. It is important to press the throttle *smoothly* since it can make your start a little jerky otherwise. Once you have a comfort level - it is easy to "glide" - coast slight grades and conserve power for prolonged rides!
- down

Footboard: The footboard is large enough that most riders can easily adjust to side-by-side riding or a "foreward - aft" stance. This is really a personal preference based on what your comfortable riding position is. Keep in mind that the rear fender (or rack) is not designed for any foot pressure. Although the aft part of the footboard is sloped up - be careful not to apply any foot pressure to the fender or it could be damaged or break and furthermore could compromise your ability to safely ride.

Kickstand: The kickstand is spring loaded and designed to retract up and out of the way. When getting ready to ride - simply place your foot on the lip of the kickstand on the ground and ease the cruiser forward allowing the kickstand to retract. It is best to use the rear tire (or rack) as a lever to help ease the cruiser off the kickstand. Similarly, when placing the cruiser back on its kickstand - it is best to place your foot down on the lip of the kickstand (holding it to the ground) use the rear tire (or rack) as leverage to help get the cruiser up to a resting position on the kickstand. **DO NOT** stand on the footboard when the kickstand is down. It is not designed to handle more than 100 lbs.

Riding Basics: It is always a good idea to plan your ride before setting off on your adventure. (see "Before you Glide" - page 3). When starting off - find your balance and "comfort zone" for foot placement. Once settled, we suggest that you do not make any moves or turns too quickly. These units are designed for slow mythical riding experiences - hence the name: "Glide Cruisers". They are **NOT** designed to be jumped or raced!

DO NOT drive off curbs or jump or your Glide! Doing so will VOID YOUR WARRANTY. RIDE AT YOUR OWN RISK.

What to Avoid:

There are a number of conditions and circumstances to avoid when riding your Glide. First, avoid riding in the rain if at all possible. Electronics and rain DO NOT mix well as a rule. If you must ride in the rain - we suggest covering the throttle, keyswitch panel and controller with plastic if possible. Next, Glide frames are designed with a "low center-of-gravity" configuration which means the belly of the frame is close to the ground. This translates into poor clearance. Sidewalks, curbs, speed bumps, etc are all things to avoid. If you go over speed bumps - take them at an angle at a very slow rate of speed unless you DON'T mind scraping your frame belly!

Lastly, although the frame geometry was designed for optimum performance - these units are not designed for extreme turns. If you were to crank out a seriously leaning turn - it would be possible that the footboard deck could hit the ground and cause the cruiser to become unstable. Glide Cruisers are designed for cruising, not racing, jumping or extreme riding! Under no circumstances should you jump your Glide. They are simply not designed for that kind of stress.

Safety Guidelines: (Top 10)

- 1. Always ride with a helmet** - Although most of the regulation out there doesn't require helmets, it is always a good idea to be on the safe side. As with riding motorcycles - it is the unknown or the unseen actions of others in cars, etc, that can create a hazard for you as a rider!
- 2. Only Ride your Glide as an individual** - Although our frames and cruiser systems are rated for up to 300 lbs, we do not recommend that more than one person ride at a time. The unique dynamics that make our stand-up cycles easy to balance and ride for one person, are seriously altered with two people. It is much harder for the driver to keep balance and safely drive the unit with another person attempting to balance and ride as well.

3. Proper braking is essential for making sure your ride is always safe - The front brake is controlled by the left lever and the rear brake by the right lever. It is a good practice to always brake "evenly" with both brakes. We engineered our cruisers to run larger diameter rotors in the rear in order to yield more stopping power to the rear caliper since most of the cruiser weight is to the rear. Although the front rotor is smaller, since you ride in a standing position - it is easier than on a standard bicycle to get lunged forward should you apply all your braking power to the front brake.

4. Always ride with eye protection to prevent debris or glare from affecting your vision and reaction time - We recommend sunglasses during the day and clear lense eyewear at night or on cloudy days.

5. Always ride with both hands on the handle bars, both feet on the foot board while in motion - Attempting to ride with one hand or one foot can seriously alter your ability to control your cruiser and can lead to accidents and/or injury.

6. Always safely operate your Glide based on current road surface conditions and weather - Use caution going down hills and around turns. Braking takes substantially longer to slow down on steep hills.

7. It is good to know the terrain, road or trail that you plan to ride - We suggest surveying your route before riding.

8. Always wear shoes and shoes that cover your toes - Should you need to step off in a hurry, it is good to know that your feet will be protected.

9. Always wear clothing that is condusive to the riding conditions. If cold out - consider wearing gloves and a hat. But DO NOT wear clothing with long straps or fabric that could possibly get caught in the wheels, motor or brakes.

10. DO NOT purposely drive off curbs or speed bumps.. Most importantly, DO NOT jump your Glide! DOING SO WILL VOID YOUR WARRANTY.

RIDE AT YOUR OWN RISK.

Cruiser Model Overview



Calisto CS1:

36 V System with Pheonix Brute Motor, mechanical disc brakes front & back and lead acid deep cycle 12Ah batteries. This is our entry-level base model. A variety of Options and accessories available for this unit.

Europa CS2:

48 V System with Pheonix Brute or Cruiser Motors, mechanical disc brakes front & back and lead acid deep cycle 15Ah batteries. Also includes wiring grid and light switches for optional light kit (running lights) and novelty Light LED kit. A variety of Options and accessories available.

Solaris CS3:

48 V System with Pheonix Brute or Cruiser Motors, hydraulic disc brakes front & back and 15Ah Lithium battery pack. Also includes light kit for front and back running lights in addition to LED novelty light kit (optional colors). A variety of Options and accessories available.

Model Specifications

Calisto CS1:

- | | |
|--|---|
| <ul style="list-style-type: none"> • 36v Electric Drive • Silent Operation • 20+ MPH Top Speed • 12Ah Lead Acid Batteries • Integrated Charging Port • Battery Life Guage • Mechanical Disc Brakes • Rear Fender | <ul style="list-style-type: none"> • Low Center of Gravity • Easy to Ride • Internal Wiring Grid • Optional Switch Panel • Sealed Battery Box • Adjust Suspension Fork • Optional Front Fender |
|--|---|

Europa CS2:

- | | |
|---|---|
| <ul style="list-style-type: none"> • 48v Electric Drive • Silent Operation • 30+ MPH Top Speed • 15Ah Lead Acid Batteries • Integrated Charging Port • Sealed Battery Box • Front / Rear Fenders | <ul style="list-style-type: none"> • Low Center of Gravity • Internal Wiring Grid • Control Switch Panel • Light Kit Connections • LED Kit Leads Installed • Mechanical Disc Brakes • Adjust Suspension Fork |
|---|---|

Solaris CS3:

- | | |
|---|--|
| <ul style="list-style-type: none"> • 48v Electric Drive • Silent Operation • 30+ MPH Top Speed • 15Ah Lithium Battery • Integrated Charging Port • Sealed Battery Box • Front / Rear Fenders | <ul style="list-style-type: none"> • Low Center of Gravity • Internal Wiring Grid • Control Switch Panel • Light Kit Installed • LED Light Kit Installed • Hydraulic Disc Brakes • Adjust Suspension Fork |
|---|--|

Component Definitions

Brake Systems - Glide installs (2) types of Disc Brake systems on its electric cruisers. Models *Calisto* and *Europa* both have "mechanical disc" brakes as standard and include pull levers, disc calipers, rotors and steel wire cables with housing as part of the brake system. Model *Solaris* features "hydraulic disc" brakes which have hydro reservoir levers, disc calipers, rotors and hydraulic hose lines charged with DOT hydraulic fluid. Our mechanical brake systems can be upgraded to hydraulic brakes as factory upgrade at time of purchase.

Tires, Wheels & Tubes - All Glide models feature a unique combination of 24" front wheels with 20" rear wheels. This gives the rider more stability and control with a stand-up configuration. Our standard tires feature an "All-Terrain" type tread geared for most common riding conditions. We install "slime" type self-healing thorn-resistant tubes on all models.

Adjustable Stem - Our adjustable stem has two points of adjustment for optimum rider positioning. Although, they both adjust the angle - the primary clamp at the top is set from the factory for standard acceptable position and is not recommended to change. The lower adjustment has 15 degrees of adjustment on the side (bolt) and is the place to make your adjustments if you would like to fine tune your handlebars positioning.

Controller - Model *Calisto* has a 36V (1440 watt) integrated 40 AMP controller and Models *Europa* & *Solaris* have a 48V (1920 watt) 40 AMP controller. The controller is the brains of the electrical drive system and interprets digital signal information between the thumb throttle, motor and battery system. It has direct connections to the APM console, throttle and motor all which have internal connections located inside the frame below the switch panel face plate.

Electric Hub Motor - Model *Calisto* has a 36V brushless hub motor and Models *Europa* & *Solaris* have a 48V brushless hub motor. Each motor is has a sealed steel housing with a main power connection cable and a controller

interface wire. The internal motor cables run the length of the frame to the controller unit with the connections located behind the keyswitch face plate.

Battery Systems - Model *Calisto* has a 36V lead acid battery system featuring (3) ea 12V 12Ah deep cycle batteries in series. Model *Europa* has a 48V lead acid battery system featuring (4) ea 12V, 15Ah deep cycle batteries in series. Our lead acid batteries are sealed low maintenance type batteries that require no maintenance except charging. The *Solaris* model features a custom 15Ah Lithium Polymer battery pack. This battery is optional for the *Europa* model. We also have a 48V, 20Ah battery pack available for models *Europa* and *Solaris*. All of our Lithium battery packs feature an on-board (BMS) battery management system computer board that balances the cells in the pack. It is critical that a base level charge is maintained in these batteries for optimal life (see page 21 for more detailed battery care instructions).

Charging Port - All models feature our all weather female XLR 3-prong plug that interfaces with the 3 Amp charger shipped with your unit.

Key & Lights Switch Panel - Models *Europa* and *Solaris* have a faceplate installed with light switches and the key switch (optional on *Calisto*). The top blue rocker switch operates both the head light and tail light. The bottom blue rocker switch operates the optional LED running lights located under the deck and in the front wheel well. In the "on position" these blue switches will light up.

Suspension Fork - all models feature an SR Suntour XCR premium adjustable coil spring 24" suspension fork. The forks are set with a preload from the factory and have a 65mm travel. You can adjust them stiffer or less stiff with the preload adjuster knob at the top of the fork (knob on the right - rider's view).

Fenders - Model *Calisto* has a rear fender only installed and models *Europa* and *Solaris* have both front and rear fenders installed. The front fender on all models has quick-release buttons to remove it if desired. For those units with optional rear cargo racks installed the standard rear fender is replaced with an integrated fender mounted permanently to the rack.

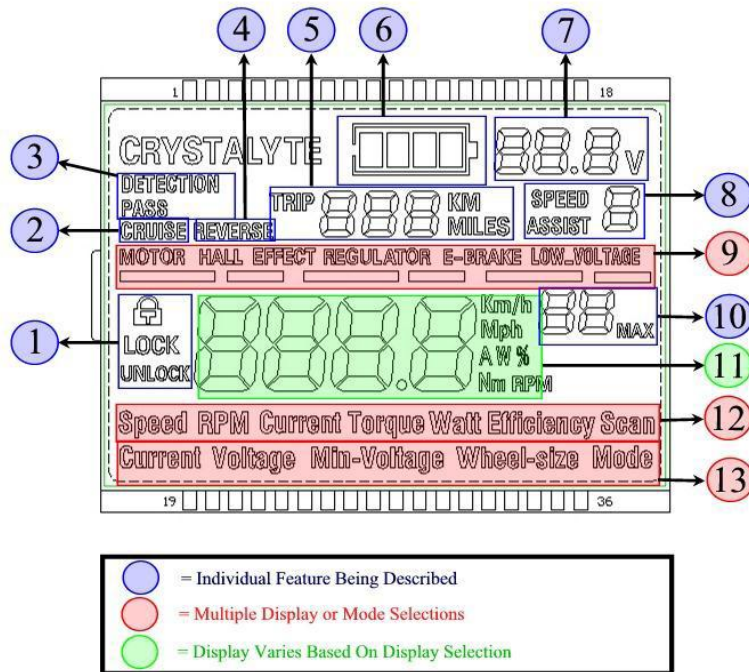

Diagram of Components

model shown: Europa CS2



APM Computer Console (optional)



Component Definitions

- (1) - **Lock/Unlock** [Icon]-Locks and unlocks the keypad.
- (2) - **Cruise** -Indicates whether the “cruise control” feature is activated.
- (3) - **Detection/Pass** -If the APM-Display senses a bad connection or failure, it will display the word “detection” while high-lighting the area in which it has been detected. **Number 9** above contains the detection options. If no failures or bad connections are detected, the word “Pass” will appear on the display.

- (4) - **Reverse** -The word “reverse” will appear when the motor’s direction of travel is reversed.
- (5) - **Tripmeter** -Displays the total distance traveled in km or miles until reset by the rider.
- (6) - **Battery Level Indicator** -Indicates battery capacity remaining. Four solid black bars indicate a fully charged battery pack. As the battery is discharged, the solid black bars disappear from right to left on the display.
- (7) - **Voltage Indicator** -Displays the voltage of the battery pack at all times while APM-Display is powered ON.
- (8) - **Speed/Assist Indicator**
Speed -The rider has a choice between 3 preset speeds when the word “speed” is displayed.
Assist -This feature is unnecessary for systems without pedal assist equipment. The assist feature acts like the speed feature in which it offers 3 preset assist options. (no assist with Glide)
- (9) - **Detection Points** -Motor/Hall effect/Regulator/E-brake/Low Voltage are all areas or points of failure the APM-Display might detect. These are connections it

checks for when powered ON. For example, if your throttle is not plugged in, the word “Regulator” may appear.



- (10) - **Maximum Speed** -Displays the maximum speed reached until the tripmeter has been reset by the rider.
- (11) - **4-digit Display** -Displays information based on the mode and settings of your display. If set to “Speed” mode, your speed will be displayed in this area. If set to “current” mode, the amount of current (amps) being used is displayed in this area. All “modes” displayed in this area are real-time.
- (12) - **Display Modes** -Speed/RPM/Current/Torque/Watt/Efficiency/Scan are all “display modes” that the rider can view while riding. These modes are all





displayed in their respective units of measurement, and in real-time. When “Scan” is selected, each display mode will appear for approx. 5 seconds before changing to the next display mode. The Scan mode allows the rider to know their current situation at any given time... almost like an instrument panel does for a pilot.





(13) - **Display Settings** –Current/Voltage/Min. Voltage/Wheel Size/Mode are all setting options. The rider **MUST** verify these settings are correct based on their system **BEFORE RIDING!** See: *Setting your APM-Display*

Adjusting the Parameters of the APM





KPH/MPH, KM/M and “CM/IN (for wheel size setting)” –Hold the DOWN  arrow for 3 seconds and both the KPH/MPH and the KM/M displays will change. **NOTE: This also changes your wheel size setting between CM/IN.** **Example: Change your display setting to MPH/Miles before you set your wheel size to 26 inches.** See: *Wheel size setting*

Voltage Setting –To set the APM-Display to the correct voltage for your system, press and hold both the UP  and DOWN  arrows until you see the word “current” flashing along with the speedometer display. Press the Power button to change from flashing the word “current” to “voltage”. When the word “voltage” is flashing, pressing the UP and DOWN arrows will cycle between 24, 48, 60, 72, and 84.

Maximum Current Setting –To set the maximum current you want the controller to provide to the motor, press and hold both the UP  and DOWN  arrows until you see the word “current” flashing along with the speedometer display. At this point, the display is in the “maximum current setting” mode. Press the UP  and DOWN  arrows to increase or decrease the number of amps (current) you wish to allow. Once you reach the desired number, wait 3 seconds for the setting to be saved.

Low Voltage Cutoff (LVC) Setting –To set the low voltage cutoff, press and hold both the UP  and DOWN  arrows until you see the word “current” flashing along with the speedometer display. Use the Power button to cycle from “current” to “voltage”, and again to “Low Voltage”. Use the UP  and DOWN 

arrows to adjust the parameters. The low voltage cutoff setting allows the rider to set the low voltage boundary at which the system will shut down. This setting makes possible the use of any battery chemistry, assuming that battery can provide the power necessary to run your system. The standard low voltage cutoff for SLA batteries is around 10.2V per 12v battery. **Example: To set the LVC for a standard 48V SLA battery pack, simply multiply 10.2V x 4 (number of 12V batteries) = 40.8V (or 41V) for the LVC setting.** **NOTE: You MUST retrieve LVC information from your battery supplier if using a battery chemistry other than SLA.**

Wheel Size Setting –To set your wheel size, hold UP  and DOWN  at the same time until you see the word “current” and the speed display **flashing**. Tap the power button several times until you see the words “wheel-size” flashing. Use the UP  and DOWN  arrows to select your wheel size in inches or centimeters, depending on whether your display is set to miles or kilometers. Left unchanged for 3 seconds, the setting will be saved. **Example: If your wheel size is 26 inches, you will press the UP  arrow until the number 26 is displayed -wait 3 seconds for it to save.**

Lock/Unlock Settings - Once you have the APM-Display set with your desired settings, you can lock your settings by holding the lock button for 3 seconds. This locks in any settings in case a button is pushed on accident. This feature works much like a cell phone button lock. To change settings at any time, simply hold the lock button again to unlock, and change the desired settings.

Display Options:

Speed –Displays your speed, real-time. The rider can choose KPH or MPH.

RPM –Displays the RPM of the motor while in motion.

Current –Displays the amount of current (Amps) being used to keep your vehicle in motion.

Torque –Displays the amount of torque your system is producing at any given time.

Watts –Displays the amount of Watts (Power) being used by your motor to keep your vehicle in motion.

General Maintenance

Your electric cruiser is virtually maintenance free. However, some of the components we install on each system may from time-to-time need adjustment. Below is a list of the items to keep under observation and some that may occasionally need adjustment:

- Tires:** Keep tires properly inflated - between 40-50 PSI (for standard all-terrain tires). If tire inflation is not kept in this range, the tube can rotate on the rim causing the tube to fail. This is especially true with the front tire.
- Brakes:** We recommend working with your local bike shop if concerned about the performance of your brakes. Hydraulic brakes may need to be bled from time to time and manual disc brakes may need slight cable adjustment. Also, brake pads may eventually need to be replaced.
- Battery:** Make sure to charge your battery pack regularly. If the battery is left uncharged for too long, it can cause damage. Normal voltage range for 48 volt batteries is 50-56 volts when completely charged.
- Fenders:** Always be sure that the bolts for fenders are tight. If too loose, locate a socket cap tool and tighten. Beware that over-tightening the front fender can cause the bracket to crack.
- Kickstand:** DO NOT stand on your cruiser footboard with the kickstand down. Follow the instructions in the Operation Section of this manual to ensure proper care (see page 5).
- Handlebars:** Your handlebars are held in place by the adjustable stem. Should the handlebars ever become loose - locate the (2) socket bolts at the top of the stem and tighten accordingly.

- Suspension:** The front suspension fork is set from the factory at medium stiffness. Should you determine that more stiffness would be better - use the tension adjustment knob at the top of the fork. Clockwise for tighter, counter-clockwise for looser.
- Frame:** Our frames are "powder-coated" and not painted. This means that the color is baked onto the frame and very durable. However, it is still possible to scratch or gouge the frame color. Should you find that you have scratched your frame - we have found that hard finish "finger nail polish" can act as a decent "touch up" paint.
- Motor:** Our Phoenix series motors are "sealed" electric motors with very few internal moving parts and thus rarely ever need any service. These are "brushless" electric motors and are controlled by an external controller and are powered by electric "current" to drive speed.
- Controller:** Our Phoenix series controllers are essentially computer driven components that receive and send digital signals to the motor via throttle position. Our controllers do not require any maintenance. However, avoid ever letting rain or running water get into the controller.

"Cleaning" - It is always good to keep your Glide clean and free of dirt and debris for optimum performance. But you should be careful HOW you go about cleaning your unit. For instance, it is easy to remove the front tire via the "dropouts" and then spray down the tire separate from the unit. DO NOT spray the throttle, controller or key / switch panel directly. This can cause electrical shorts. We suggest hand cleaning the frame with a wet cloth first then drying with a dry towel. For deeper cleaning, you can remove the footboard (clean / spray separately) and then remove the battery to clean out the battery box. DO NOT EVER get the battery or the BMS (battery management system) wet! Doing so can cause battery failure and permanent damage.

Battery Care & Maintenance

Our deep cycle **Lead Acid** batteries are completely sealed and require no maintenance except basic charging. Lead Acid batteries in general, will slowly lose full charge capacity over time (usually 1 year or less). The only thing to watch for on the Lead Acid batteries is that the terminal connections are properly secure at each terminal position.

Lithium batteries are typically designed to last much longer. Our Lithium batteries are engineered to produce between 1000 and 1500 charge cycles if properly cared for. At 1500 cycles the expected charge production is 75% capacity. Therefore, maintain a regular charge and follow the basic guidelines below:

1. *The most important thing to remember is to maintain a base charge.* Do not allow your battery to drain completely. If you let the battery sit for more than one month, it may permanently damage the battery.
2. *Keep your battery protected from the elements.* As with any battery, extreme heat, cold, water, humidity, etc. can cause damage to your battery. The primary thing to remember is -- DO NOT ever let water get to the battery packs or BMS (battery management system). Doing so could cause permanent damage to your battery system!
3. *If installing or removing batteries - make sure that the connections are made correctly.* The best policy is the "go slow" and mythical when working with connections and wiring. BE SURE the RED wire to RED wire (positive) and BLACK wire to BLACK wire (negative) connections are made correctly when installing or removing the battery.
4. *The order for connecting the (2) battery bricks together on the Lithium Battery packs should be:* The big RED connector (Anderson Connector) between the packs - connected first, then the multi-pin connector next. Go slow and make sure they go together easily and without excessive force. You can damage the multi-pin connector especially if improperly forced. (see picture 1)



5. When removing the Lithium Battery pack in your unit - follow these steps:
 - a. Carefully lift the back part of the battery pack up first and then slide the entire pack slightly back to allow easy access to the BMS and other wires located at the front.
 - b. Next, carefully lift the pack up and out of the frame to the side of the frame without stressing the connections.
 - c. Disconnect the big all-weather Red / Black connector first (the main power connection with the largest wires).
 - d. Next, disconnect the small Black "ground" wire (single connection). You will need to remove the black electrician's tape securing the connection.
 - e. Lastly, disconnect the charger lead (red / blue wire). Again, you will need to remove the black electrician's tape securing the connection.

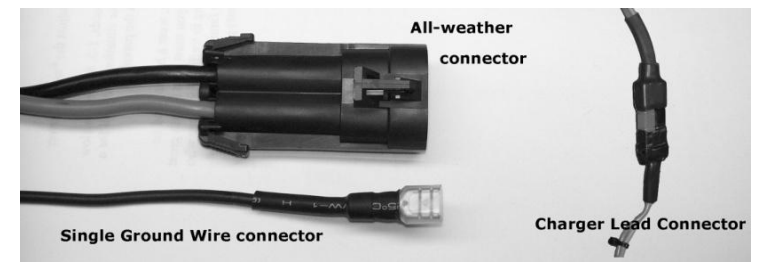

6. When installing the Lithium Battery pack - follow instructions above in (5) in reverse. Use fresh electrician's tape to secure the (2) connectors listed in 5d, 5e.

Troubleshooting

Your Glide Cruiser is designed to function with relatively few mechanical or electrical issues. Because you choose a Glide electric cruiser over any product with a combustion engine, your maintenance and number of possible problems has been reduced by hundreds of parts. Your Glide is easy to use, service and maintain. But should you encounter any technical issues - here are some troubleshooting guidelines.

1. Your charger is not charging
 - a. Not plugged in to 120Vac source (red power light should be "on" located on your charger)
 - b. Power cord from charger is not fully plugged in to the Glide XLR receptacle on the frame (firmly insert the plug to ensure proper contact)
 - c. Wall plug end of the charger plug is not secure in the charger unit. (firmly insert the plug to ensure proper contact)
 - d. Loose or damaged Main Breaker fuse (make sure that the big red 50amp fuse on the primary Red power wire inside the frame is undamaged)
 - e. Be sure to check the fuse located on the charger.
 - f. Defective power supply (if no lights appear on the power supply, it is likely damaged)
2. Battery does NOT seem to hold a charge
 - a. Possible bad connection between your charger and the battery. Check all connectors to the battery pack.
 - b. Charger may be damaged. Review the charger light indicators and fuse for proper function.

- c. Measure voltage of the battery pack. Battery pack should read 42 volts DC or higher. This is a task for a qualified powersports technician or contact Glide for instructions on how to conduct measurement.
 - d. If the battery pack reads under 42 volts DC, there may be a damaged battery cell. Your battery pack contains two 12 VDC bricks with internal cells. A qualified powersports technician can service the pack or a new pack can be ordered through Glide Cruisers, USA. (Always recycle old batteries in a proper manner.)
3. When I turn on the ignition key, the Glide lights and electrical systems function, but Cruiser will not accelerate or move
 - a. Check the Controller to see if the "red" power light is on. If not make sure that the switch at the bottom of the controller is also switched on. If switched on, and still no power light - contact your Glide dealer for further diagnosis.
 - b. Check the lighted throttle to make sure there is power from the source and if not - check the connector to verify proper connection.
4. Brakes are not working properly
 - a. Locate a qualified mountain bike technician or repair facility to inspect and/or replace worn or contaminated brake pads, adjust levers or bleed hydraulic brakes if needed.

Troubleshooting Cont'd

5. Cannot inflate flat tire
 - a. Inspect tire to determine if damaged in any way, locate a qualified mountain bike technician or repair facility to inspect and/or replace the tube and/or tire if needed.
6. The throttle does not work or move the Cruiser
 - a. If the throttle does not return to a stop position, the throttle spring may be damaged - contact your Glide dealer for further diagnosis or replacement.
 - b. If the cruiser motor moves without depressing the thumb throttle - you may have water or condensation inside the throttle causing a short. Let it dry for 24 -36 hours or remove the throttle from the handlebars to speed the drying process.
 - c. Make sure Power Indicator light at the thumb throttle is on. If not, check the connection to the controller. (This connection is located at the top of the controller.) Call Glide technical support for further diagnosis assistance or guidance.

Warranty

All of the Glide Electric Cruiser models carry a general (1) one year warranty - with exception to several electrical components which carry original manufacturer warranty's as follows:

Motor - (90) day warranty

Battery - (90) day warranty

Controller - (90) day warranty

Throttle - (90) day warranty

The electrical systems included on your Glide Cruiser are designed to last for years if properly cared for. However, if neglected and/or abused - the electrical components (listed above - especially the battery) will not last to their potential. This is why the original manufacturers of these items have a relatively short warranty's for their products. Each rider experience is different, but if you care for your cruiser properly and ride with caution - you will enjoy years of performance and fun!

Accessories - Glide Cruisers is a private label reseller of many of the accessories in the Glide line. For those items not made by Glide, we will honor the original manufacturer warranty period and assist in servicing any issue with those manufacturers. Call for specific accessory warranties. For those items manufactured by Glide we support a (1) year original manufacturer's warranty.